

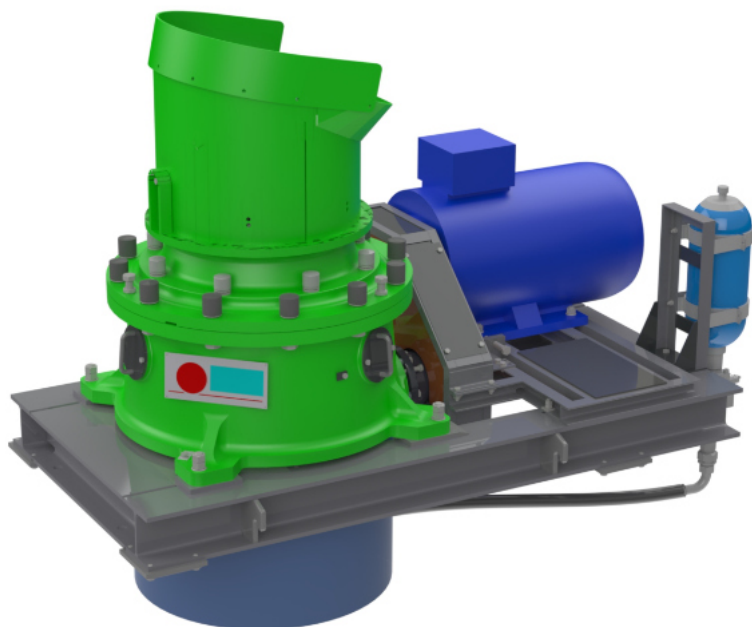

# KEGELBRECHER

## Vorteile

- ✓ pvollautomatischer Betrieb des Brechers inklusive Spalteinstellung
- ✓ niedrige Betriebskosten
- ✓ hohe Betriebszuverlässigkeit
- ✓ hohe Zerkleinerungsgrad
- ✓ bedienungs und wartungsarm
- ✓ Brechwerkzeuge mit langer Lebensdauer
- ✓ hohe Qualität des Endprodukts



Typ	Einlauf [mm]	Spalt [mm]	Durchsatz [t/h]	El. motor [kW]	Brechraum - Optionen
KDC 22	150-170	19-35	8-180	3	HP
KDC 32	8-90	4-25	30-120	5,5	SP, JP, FP
KDC 23	175-245	20-50	135-265	18	VP, HP
KDC 33	35-135	6-32	80-200	37	SP, JP, GP, FP
KDC 24	200-280	22-57	140-400	75	VP, HP
KDC 34	40-150	7-34	80-300	110	SP, JP, GP, FP
KDC 27	250-380	22-65	290-800	110	VP, HP, SH
KDC 37	40-200	10-45	160-500	132	SP, SJ, JP, GP, FP

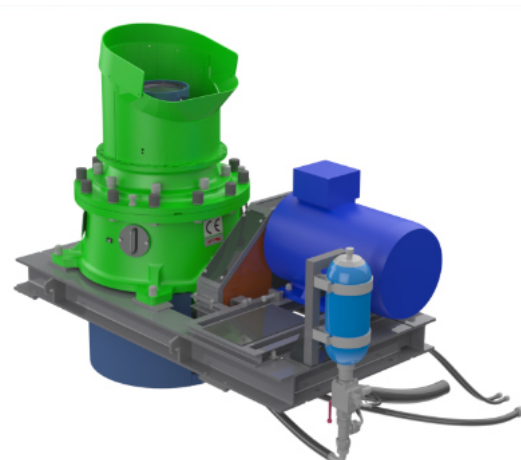
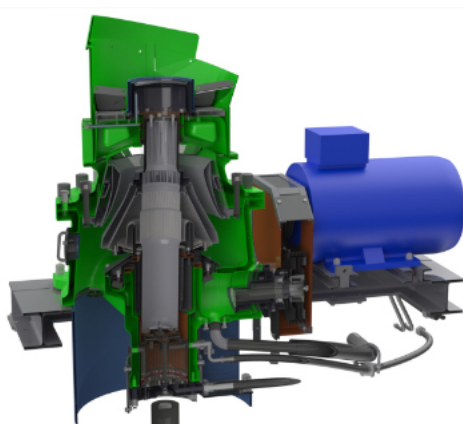
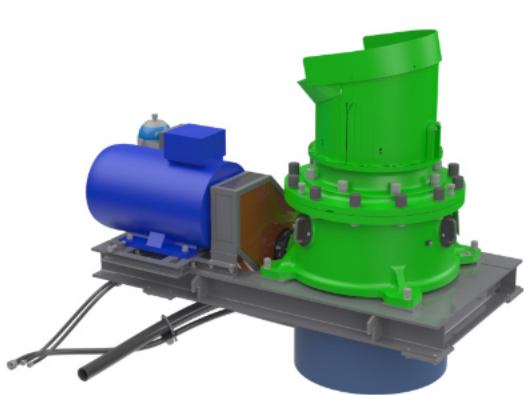

RESTA s.r.o.  
IČO: 14616807  
DIČ: CZ 14616807

Kojetínská 3120/75  
750 02 Přerov  
Tschechische Republik

✉ [resta@resta.cz](mailto:resta@resta.cz)  
☎ +420 581 741 811

[www.resta.cz](http://www.resta.cz)